



PRODUCT SPECIFICATION

产品规范

适用于 For
K823 GNSS 模块
K823 GNSS Module



INTRODUCTION

©2024, Comnav Technology Ltd. All rights reserved. SinoGNSS is the trade mark of Comnav Technology Ltd. registered in People's Republic of China. All other trademarks are the property of their respective owners.

REVISION HISTORY / 修订历史

Revision/版本	Modification/更改	Date/日期
1.0	New Release / 新发	2023/08/31
1.1	Delete LDO paragraphs / 删除LDO段落	2023/11/28
1.2	Modify the physical picture / 修改实物图	2024/08/08
1.3	Modify some product specifications / 修改部分产品参数	2024/10/21

DIRETORY / 目录

REVISION HISTORY / 修订历史.....	2
DIRETORY / 目录.....	3
1. Introduction / 简介.....	4
1.1. Product Characteristics / 产品特性.....	4
2. Size / 尺寸.....	9
3. Pin Arrangement and Definition / 针脚标识和定义.....	11
3.1. Remarks / 说明.....	13
4. Assembling & Repairing Note / 装配及维修说明.....	18
4.1. Module Assembling Note / 模块装配说明.....	18
4.2. Repairing Note / 维修说明.....	19
5. Application Connection Example / 应用连接示例.....	20
6. Package / 包装.....	23
Figures	
Figure 1. K823 Product Photo / K823 实物图.....	9
Figure 2. K823 Dimension View / K823 三视图.....	9
Figure 3. K823 Bottom Section View / K823 底部部分视图.....	10
Figure 4. K823 Includes 60-Pin Pad / K823 包括60连接焊盘.....	11
Figure 5. Furnace Temperature Curve / 炉温曲线.....	18
Figure 6. Connections between RS232 COM1, 2, 3 of K823 and Some Other Devices with An UART / K823 RS232 COM1、2、3与其他使用UART接口的设备之间的连接示意.....	20
Figure 7. Minimum Hardware Design of K823 / K823 最小硬件设计.....	21
Figure 8. Recommend Design of K823 / K823 推荐硬件设计.....	22
Figure 9. K823 Roll Tape Packing / K823 卷带包装.....	23
Tables	
Table 1. Product Characteristics / 产品特性.....	4
Table 2. Pin Definition of K823 60-Pin Pad / K823 60针脚焊盘的针脚定义.....	12
Table 3. LVCMOS 3.3V Electrical Standard / LVCMOS 3.3V电气标准.....	13
Table 4. LVTTTL 3.3V Electrical Standard / LVTTTL 3.3V电气标准.....	14
Table 5. K823 Package Description / K823 包装说明.....	23

1. Introduction / 简介

K823 GNSS is a full-system and multi-frequency RTK positioning and heading module developed by SinoGNSS based on Quantum III Soc with fully independent intellectual property rights. It supports BDS-2, BDS-3, GPS, GLONASS, Galileo, QZSS, IRNSS and other satellite system signals, contains onboard IMU, supports integrated navigation and is suitable for surveying and mapping, robotics, foundation enhancement and other fields.

K823 GNSS是司南导航基于具有完全自主知识产权的Quantum III开发的全系统多频点RTK定位定向模块，支持BDS-2、BDS-3、GPS、GLONASS、Galileo、QZSS、IRNSS等卫星系统信号跟踪，板载IMU，支持组合导航，适用于测量测绘、机器人、地基增强等领域。

1.1. Product Characteristics / 产品特性

Table 1. Product Characteristics / 产品特性

Characteristics		K823
Signals 信号	Positioning & Heading 定位&定向	GPS: L1C/A, L2P, L2C
		BDS-2: B1I, B2I, B3I*
		BDS-3: B1I, B1C, B2a, B2b, B3I*
		GLONASS: G1, G2*
		Galileo: E1, E5b, E5a, E6c
		QZSS*: L1C/A, L2C
		SBAS*: L1C/A
Items with * will be adjusted with the version. 带*项会随同版本进行调整。		
Time to First Fix 首次定位时间	Cold Start 冷启动	<20s
	Hot Start (with RTC) 热启动 (使用RTC)	<10s (Typical,典型)

Signal Capture 信号捕获	Reacquisition 失锁重捕	<1s
	Signals Tracking Sensitivity 信号跟踪灵敏度	-155dBm
	Signal Capture Sensitivity 信号捕获灵敏度	-138dBm
Measurement Precision 测量准确度	Pseudo-range Precision 伪距精度	≤10cm
	Carrier Phase Precision 载波相位精度	≤1mm
Accuracy 精度	PPS (RMS) 授时精度	20ns
	SPP Accuracy 标准单点定位精度	H≤1.5m, V≤3m (1σ, PDOP≤4)
	Static Differential Accuracy (Supported by Compass Solution) 静态差分精度 (Compass Solution软件支持)	H:±(2.5+1×10 ⁻⁶ ×D)mm V:±(5.0+1×10 ⁻⁶ ×D)mm D为基线长度 (单位: mm) D-Baseline length (Unit: mm)
	Speed Accuracy 测速精度	≤0.02m/s (1σ, PDOP≤4)
PPP	PPP Convergence Time PPP初始化时间	<20min
	PPP Accuracy	H≤10cm, V≤20cm

	PPP精度	
RTK	RTK Initialization Time RTK初始化时间	<5s (D<10km)
	Initialization Reliability 初始化置信度	>99.9%
	RTK Accuracy RTK精度	H:±(8+10 ⁻⁶ ×D)mm V:±(15+10 ⁻⁶ ×D)mm D为基线长度(单位: mm) D-Baseline length (Unit: mm)
Attitude Accuracy 测姿精度	Azimuth Accuracy 方位角精度	(0.15/R)°, R is baseline length in meter. R为基线长度, 单位为米
	Roll or Pitch Accuracy 横滚或俯仰角	(0.25/R)°, R is baseline length in meter. R为基线长度, 单位为米
Anti-interference 抗干扰	K823 is built-in narrowband and continuous wave suppression algorithm engine K823 内置窄带和连续波抑制算法引擎	
Inertial Navigation 组合导航	While the GNSS antenna signal is losing lock for 3 seconds, the accuracy maintains at centimeter level. While the GNSS antenna signal is losing lock for 10 seconds, the accuracy maintains at meter level. GNSS天线信号失锁 3s, 精度保持cm级 GNSS天线信号失锁 10s, 精度保持m级	
IMU	Gyroscope 陀螺仪	Measurement ranges 量程: ±125°/s
		Zero-biased stability 零偏稳定性: 10°/h

		Angular random walk 角度随机游走: $0.3^{\circ}/\sqrt{h}$
	Accelerometer 加速度计	Measurement ranges 量程: $\pm 4g$
		Bias instability 零偏稳定性: $70\mu g$
		Velocity random walk 速度随机游走: $0.16m/s/\sqrt{h}$
Data Rates 数据速率	Measurements & Position 测量&定位	Max 20Hz (Optional, 选配项)
	RTK: Positioning RTK: 定位	Max 20Hz (Optional, 选配项)
	IMU	Max 50Hz (Optional, 选配项)
Data Formats 输出数据格式	NMEA-0183	GPGGA, GPGSV, GPGLL, GPGSA, GPGST, GPHDT, GPRMC, GPVTG, GPZDA etc.
	ComNav Binary (CNB) 司南二进制格式	ComNav Self-Defined Binary 司南自定义二进制
	CMR(GPS)	CMROBS, CMRREF
	RTCM2.X	RTCM1, RTCM3, RTCM31
	RTCM3.X	1004~1008,1012,1019,1020,1033,1042,1045/1046, 1230 MSM3~MSM7:1073~1077,1083~1087,1123~1127,1093~1097
Electrical 电气特性	Voltage 供电电压	+ 3.3V~3.45V DC

©2024, Comnav Technology Ltd. All rights reserved. SinoGNSS is the trade mark of Comnav Technology Ltd, registered in People's Republic of China. All other trademarks are the property of their respective owners.

	Power Consumption 功耗	1.6W
Environmental 环境要求	Operating Temperature 工作温度	-40°C~+85°C
	Storage Temperature 储存温度	-55°C~+95°C
Antenna Interface 天线接口	Impedance Matching 阻抗匹配	50Ω
	Antenna Power 天线供电电压	External 外部供电: +3.3V~+5V @ (0-100) mA
	Antenna Gain 天线增益	20~35dB
Hardware Interface 硬件接口	UARTx3, PPSx1, EVENTx2, SPIx1	
Physical 物理参数	Size 尺寸	30mm×40mm×3.2mm
	Weight 重量	9.4g
	Flatness 平整度	≤0.1mm
	Package 封装	LGA (60PIN)

2. Size / 尺寸

In this section, product photo, three-side views and the dimension of K823 is provided for customers' further hardware design and installation.

本节提供了K823的实物图，三视图和对应的物理尺寸，便于用户进一步系统硬件设计和安装。



Figure 1. K823 Product Photo / K823 实物图

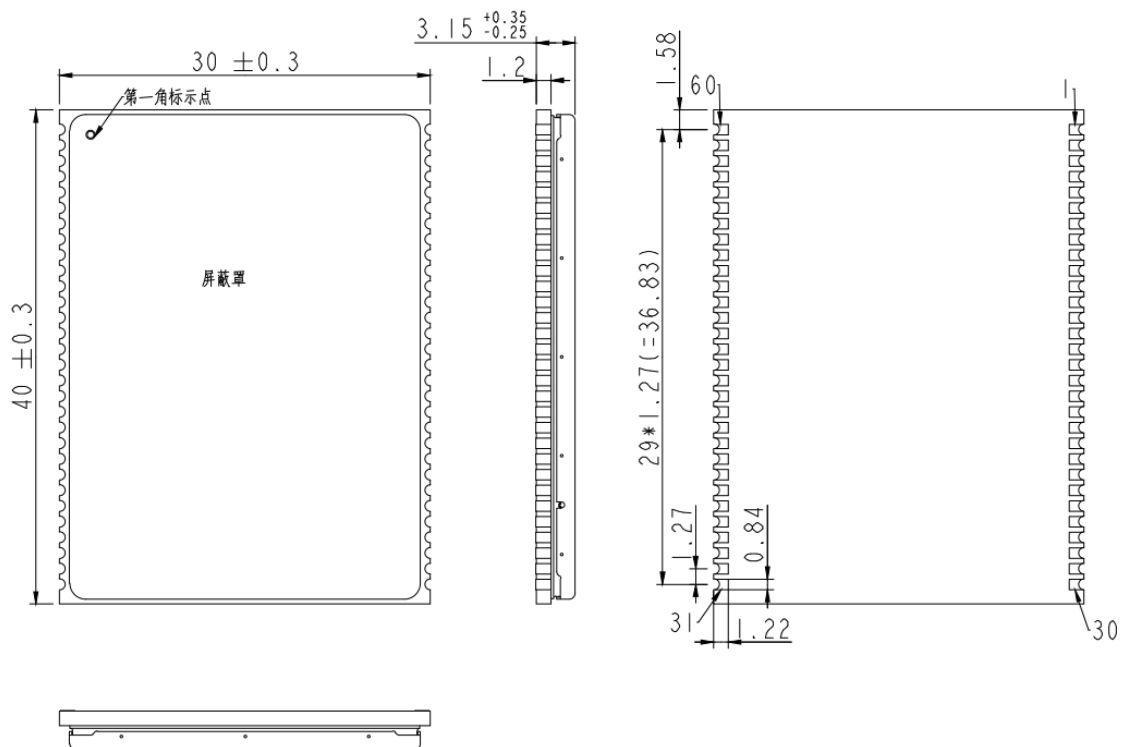

Figure 2. K823 Dimension View / K823 三视图

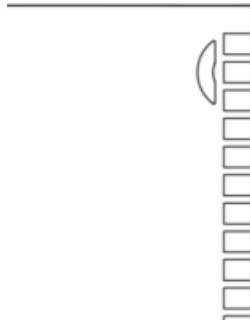

Figure 3. K823 Bottom Section View / K823 底部部分视图

Note: Because there is a half-moon window exposed tin position near the bottom of K823 module 62Pin, it is recommended that the pad should not be expanded outward when the user is packaged, otherwise it will be short-circuited.

注意：因为K823模块62Pin附近底部有半月形开窗露锡位置，建议用户封装时，焊盘尽量不要往外扩，否则会短路。

3. Pin Arrangement and Definition / 针脚标识与定义

K823 is surface-mount OEM Module which integrates 60 Pin (pitch 1.27mm).

K823包括60Pin, 表贴式模块 (pitch 1.27mm)。

1	GND	GND	60
2	ANT1_IN	ANT2_IN	59
3	GND	GND	58
4	GND	GND	57
5	ANT1_PWR	ANT2_PWR	56
6	GND	GND	55
7	ANT1_OPEN	ANT2_OPEN	54
8	ANT1_SHORT	ANT2_SHORT	53
9	GND	GND	52
10	RSV	RSV	51
11	RSV	RSV	50
12	RSV	RSV	49
13	EVENT2	RSV	48
14	GND	GND	47
15	RSV	RST_N	46
16	RSV	EVENT1	45
17	V_BACKUP	PPS	44
18	GND	GND	43
19	PVT_STAT	RSV	42
20	PVT2_STAT	RSV	41
21	RSV	COM3_RXD	40
22	FRESET_N	COM3_TXD	39
23	RSV	COM2_RXD	38
24	RTK_STAT	COM2_TXD	37
25	GND	COM1_RXD	36
26	SPI_MISO	COM1_TXD	35
27	SPI_MOSI	GND	34
28	SPI_CLK	GND	33
29	SPI_CS	VIN	32
30	RSV	VIN	31

Figure 4. K823 Includes 60-Pin Pad / K823 包括60连接焊盘

Table 2. Pin Definition of K823 60-Pin Pad / K823 60针脚焊盘的针脚定义

Pin	Signal	Type	Description	
1	GND	GND	Ground Reference	参考地
2	ANT1_IN	I	GNSS Positioning antenna	GNSS定位天线
3~4	GND	GND	Ground Reference	参考地
5	ANT1_PWR	PWR (I)	Power supply for external GNSS Positioning antenna LNA	外部GNSS定位天线供电
6	GND	GND	Ground Reference	参考地
7	ANT1_OPEN	O	Open Indication of Positioning Antenna	定位天线断路指示 (低有效)
8	ANT1_SHORT	O	Short Indication of Positioning Antenna	定位天线短路指示 (低有效)
9	GND	GND	Ground Reference	参考地
10~12	RSV	/	Reserve (Float)	保留管脚 (悬空)
13	EVENT2	I	Event Mark	外部事件输入
14	GND	GND	Ground Reference	参考地
15~16	RSV	/	Reserve (Float)	保留管脚 (悬空)
17	V_BACKUP	PWR	Power Supply for Internal RTC	外接RTC电池
18	GND	GND	Ground Reference	参考地
19	PVT_STAT	O	PVT Status	定位天线搜星时, 模块搜星数与高电平脉冲数一致; 不搜星时, 5S输出一次高电平
20	PVT2_STAT	O	PVT2 Status	定向天线搜星时, 模块搜星数与高电平脉冲数一致; 不搜星时, 5S输出一次高电平
21	RSV	/	Reserve (Float)	保留管脚 (悬空)
22	FRESET_N	I	Reset to Factory Mode, Active Low	复位为出厂模式, 低电平有效
23	RSV	/	Reserve (Float)	保留管脚 (悬空)
24	RTK_STAT	O	RTK Data LED Indicator	在接收或发送差分信号时会输出高电平脉冲, 其他状态输出低电平
25	GND	GND	Ground Reference	参考地
26	SPI_MISO	I	SPI_MISO	SPI主输入从输出信号
27	SPI_MOSI	O	SPI_MOSI	SPI主输出从输入信号
28	SPI_CLK	O	SPI_CLK	SPI总线时钟信号
29	SPI_CS	O	SPI_CS	SPI总线片选信号
30	RSV	/	Reserve (Float)	保留管脚 (悬空)
31~32	VIN	PWR	DC Power Supply for Module (+3.3V)	模块供电电源 (+3.3V)
33~34	GND	GND	Ground Reference	参考地
35	COM1_TXD	O	Transmitted Data for COM 1 Output	串口1输出信号
36	COM1_RXD	I	Received Data for COM 1 Input	串口1输入信号

Pin	Signal	Type	Description	
37	COM2_TXD	O	Transmitted Data for COM 2 Output	串口2输出信号
38	COM2_RXD	I	Received Data for COM 2 Input	串口2输入信号
39	COM3_TXD	O	Transmitted Data for COM 3 Output	串口3输出信号
40	COM3_RXD	I	Received Data for COM 3 Input	串口3输入信号
41~42	RSV	/	Reserve (Float)	保留管脚 (悬空)
43	GND	GND	Ground Reference	参考地
44	PPS	O	Pulse Output Synchronized to OEM Time	同步卫星时间脉冲
45	EVENT1	I	Event mark	外部事件输入
46	RST_N	I	Quick Reset without Clearing User Configuration (Low Active)	快速复位, 不清除用户配置 (低电平有效)
47	GND	GND	Ground Reference	参考地
48~51	RSV	/	Reserve (Float)	保留管脚 (悬空)
52	GND	GND	Ground Reference	参考地
53	ANT2_SHORT	O	Short Indication of Orientation Antenna (Low Active)	定向天线短路指示 (低电平有效)
54	ANT2_OPEN	O	Open Indication of Orientation Antenna (Low Active)	定向天线断路指示 (低电平有效)
55	GND	GND	Ground Reference	参考地
56	ANT2_PWR	PWR (I)	Power Supply for External GNSS Orientation Antenna LNA	外部GNSS定向天线供电
57~58	GND	GND	Ground Reference	参考地
59	ANT2_IN	I	GNSS Orientation Antenna	GNSS定向天线
60	GND	GND	Ground Reference	参考地

Items with * will be adjusted with the version.
带*项会随同版本进行调整。

3.1. Remarks / 说明

1. Electrical Characteristics / 电气特性

COM1/2/3(TX&RX), SPI, ANT1/2(OPEN&SHORT), PVT1/2_STAT, FRESET_N, RTK_STAT, RST_N, PPS, EVENT and EVENT2 are LVCMOS 3.3V level, All these signals are LVCMOS/LVTTL 3.3V compatible.

COM1/2/3 (TX&RX), SPI, ANT1/2 (OPEN&SHORT), PVT1/2_STAT, FRESET_N, RTK_STAT, RST_N, PPS, EVENT 和 EVENT2 为 LVCMOS 3.3V 电平, 所有这些信号均兼容 LVCMOS / LVTTL 3.3V。

Table 3. LVCMOS 3.3V Electrical Standard / LVCMOS 3.3V电气标准

Symbols 符号	Description 描述	Min 最小	Max 最大
V _{IH}	Input high voltage 输入高电压	2.0V	VCC+0.3V

©2024, Comnav Technology Ltd. All rights reserved. SinoGNSS is the trade mark of Comnav Technology Ltd, registered in People's Republic of China. All other trademarks are the property of their respective owners.

V_{IL}	Input low voltage 输入低电压	-0.3V	0.8V
V_{OH}	High-level output voltage 高电平输出电压	VCC-0.4V	--
V_{OL}	Low-level output voltage 低电平输出电压	--	0.41V
I_{OH}	Sourcing current 拉电流		8mA
I_{OL}	Sinking current 灌电流		8mA

Table 4. LVTTTL 3.3V Electrical Standard / LVTTTL 3.3V电气标准

Symbols 符号	Description 描述	Min 最小	Max 最大
V_{IH}	Input high voltage 输入高电压	2.0V	VCC+0.3V
V_{IL}	Input low voltage 输入低电压	-0.3V	0.8V
V_{OH}	High-level output voltage 高电平输出电压	VCC-0.4V	--
V_{OL}	Low-level output voltage 低电平输出电压	--	0.41V
I_{OH}	Sourcing current 拉电流		8mA
I_{OL}	Sinking current 灌电流		8mA

2. Can withstand Voltage Range / 能承受的电压范围

The signal with the maximum voltage range from -0.3V to 3.6V is as follows: COM1/2/3(TX&RX), SPI, ANT1/2(OPEN&SHORT), PVT1/2_STAT, FRESET_N, RTK_STAT, RST_N, PPS, EVENT and EVENT2.

所能承受电压的最大值范围是-0.3V~3.6V的信号如下：COM1/2/3 (TX&RX)，SPI，ANT1/2 (OPEN&SHORT)，PVT1/2_STAT，FRESET_N，RTK_STAT，RST_N，PPS，EVENT和EVENT2。

3. Supply Voltage / 供电电压

VIN main power supply, voltage range: 3.3V~3.45V (DC), voltage ripple and spikes require less than 50mV. K823: ANT_PWR, voltage range: 3.3V ~ 5.5V (DC), voltage ripple and spikes require less than 50mV. V_BACKUP operating voltage 1.8V~3.6V, voltage ripple and spike pulse requirements are less than 30mV; When charging the Farrah capacitor, V_BACKUP voltage reference circuit, voltage ripple and spike pulse requirements are less than 30mV.

VIN主供电电源，电压范围：3.3V~3.45V（直流），电压纹波和尖峰脉冲要求小于50mV。K823: ANT_PWR，电压范围：3.3V~5.5V（直流），电压纹波和尖峰脉冲要求小于50mV。V_BACKUP工作电压1.8V~3.6V，电压纹波和尖峰脉冲要求小于30mV；给法拉电容充电时，V_BACKUP电压参考电路，电压纹波和尖峰脉冲要求小于30mV。

4. Add Surge Protection / 增加浪涌保护

In order to effectively protect against lightning strikes and surges, and prevent damage to the feed current limiting chip inside the module, it is recommended that users supply power to the antenna from outside the module and increase the surge protection function.

If you need to feed the antenna from the outside, it is recommended to use a high-voltage, high-power feeder chip; or add high-power protection devices such as gas discharge tubes, varistors, and TVS tubes to the feeder circuit.

为了有效防雷击、防浪涌，防止模块内部的馈电限流芯片损坏,建议用户从模块外部给天线供电并增加浪涌保护功能。

如需从外部为天线馈电，建议选用高耐压、大功率的馈电芯片；或在馈电电路上增设气体放电管、压敏电阻、TVS管等大功率的防护器件。

5. Antenna Short Circuit Description / 天线短路说明

When using the internal feed of the board, the following situations will occur:

- 1) When the antenna is normal, Pin 7, 8, 53 and 54 output high level;
- 2) When antenna ANT1 is short circuited, Pin 8 outputs low level and Pin 7 outputs high level; When antenna ANT2 is short circuited, Pin 53 outputs low level and Pin 54 outputs high level;
- 3) When antenna ANT1 is disconnected (no antenna is connected), Pin 8 will output high level and Pin 7 will output low level; When antenna ANT2 is disconnected (no antenna is connected), Pin 53 outputs high level and PIN 54 outputs low level.

当使用板卡内部馈电时，会出现如下情况：

- 1) 天线正常时，Pin 7、8、53和54输出高电平；
- 2) 天线ANT1短路时，Pin 8输出低电平，Pin 7出高电平；天线ANT2短路时，Pin 53输出低电平，Pin 54出高电平；
- 3) 天线ANT1断路（没接天线）时，Pin 8输出高电平，Pin 7出低电平；天线ANT2断路（没接天线）时，Pin 53输出高电平，Pin 54出低电平。

6. Hardware Integration Considerations / 硬件集成注意事项

- 1) VCC power-on has a good monotonicity, and the initial level is lower than 0.4V, and the upstroke and ringing are guaranteed within the range of 5% VCC;

©2024, ComnavTechnology Ltd. All rights reserved. SinoGNSS is the trade mark of Comnav Technology Ltd, registered in People's Republic of China. All other trademarks are the property of their respective owners.

- 2) Use the VCC pin to provide a reliable power supply and all GND pins of the module are grounded;
- 3) Connect the ANT_IN signal to the antenna, pay attention to the 50Ω impedance matching of the line;
- 4) The ANT_PWR pin is connected to +3.3~5.5V voltage, and then provides +3.3~5.5V feed to the antenna through the ANT_IN pin;
- 5) The module reset pin FRESET_N is for restoring the factory settings of the module, and RST_N is for quick reset. Please connect it correctly to ensure that the module can be reset reliably;
- 6) Special attention should be paid to:
Power supply: The guarantee of stable and low ripple power supply, the peak-to-peak value of the ripple voltage is preferably not higher than 50mVpp. It is recommended to use a power chip with a current output capacity greater than 2A to supply power to the module.
In addition to using LDO to ensure the power supply is pure, it is also necessary to consider:
 - ①. Widening the power traces or using split copper surfaces to transmit current;
 - ②. Place the LDO as close to the module as possible in the layout;
 - ③. Avoid the power traces passing through high power with high inductance devices such as magnetic coils.
- 7) Antenna interface: The antenna line is as short and smooth as possible, avoiding acute angles; pay attention to 50Ω impedance matching;
- 8) Avoid wiring directly under K823;
- 9) The module is as far away from the high temperature airflow as possible.

- 1) VCC上电具有良好的单调性，且起始电平低于0.4V，上冲与振铃保障在5%VCC范围内；
- 2) 用VCC引脚提供可靠的电源且模块所有GND引脚接地；
- 3) 连接ANT_IN信号至天线，注意线路50Ω阻抗匹配；
- 4) ANT_PWR脚接入+3.3~5.5V电压，再经由ANT_IN脚对天线提供+3.3~5.5V的馈电；
- 5) 模块复位引脚FRESET_N为恢复模块出厂设置，RST_N为快速复位，请正确连接以保证模块可以可靠复位；
- 6) 在设计中应特别注意：
供电：稳定及低纹波电源的保证，纹波电压峰值最好不高于50mVpp。建议采用电流输出能力大于2A的电源芯片给模块供电。
除了可采用LDO保证供电纯净外，还需要考虑：
 - ①. 加宽电源走线或采用分割铺铜面来传输电流；
 - ②. 布局上尽量将LDO靠近模块放置；
 - ③. 电源走线避免经过大功率与高感抗器件如磁性线圈。
- 7) 天线接口：天线线路尽量短且顺畅，避免走锐角；注意50Ω阻抗匹配；
- 8) 避免在K823正下方走线；
- 9) 模块尽量远离高温气流。

7. Static Electricity Protection / 静电保护

Some components on K823 module are easily damaged by static electricity, which in turn affects the IC circuit and other components. Therefore, you should pay attention to electrostatic protection measures when using it.

- 1) When handling the module, try to wear gloves or finger cots and an anti-static wrist strap that meets the electrostatic protection standards;

- 2) During the process of taking the module, only the edge of the board should be taken, and the solder joints, circuit parts or components should not be directly touched to avoid sweat fingerprints from contaminating the solder joints;
- 3) The module should be protected by a soft protective pad between the module and the module interval during transportation;
- 4) When the module is idle, it should be placed on a soft protective pad (such as anti-static sponge pad, etc.), and do not stack at will;
- 5) The modules should be placed neatly and orderly, with a certain interval between modules to avoid collision with each other;
- 6) The module should be handled with care during use to prevent the module from being damaged by rough operation;
- 7) When powering on, pay attention to the positive and negative poles of the power supply and the voltage to avoid reverse connection and excessive voltage from burning the module;
- 8) When soldering the module to the motherboard, please ensure that the GND is soldered first, and then the ANT_IN pin;
- 9) When handling ANT_IN pin, do not touch any live capacitance or material (e.g., surface mount antenna, coaxial cable, wire iron, etc.) to avoid damage to the ANT_IN pin by the charge generated or stored by said capacitor or material;
- 10) Please make sure to solder the ANT_IN pin with an electrical protection iron.

K823模块上的部分元器件易受静电影响而损坏，进而影响IC电路及其他元件。因此在使用时应注意做好静电保护措施。

- 1) 拿取模块时应尽量戴好手套或者指套以及符合静电防护标准的防静电腕带；
- 2) 模块拿取过程中应只拿取板卡的边缘部位，不能直接接触焊点，线路部分或者元器件，避免汗液指印污染焊点；
- 3) 模块在运输过程中模块与模块间隔之间应该采用软性防护垫进行保护；
- 4) 模块闲置时应放置在软性防护垫上（如防静电海绵垫等），不要随意堆叠；
- 5) 模块摆放应摆放整齐有序，模块之间保持一定间隔，避免相互碰撞；
- 6) 模块在使用过程中应该轻拿轻放，防止粗暴作业损坏模块；
- 7) 上电时，注意电源正负极以及电压，避免反接和电压过高烧毁模块；
- 8) 将模块焊接到主板时，请确保GND先焊接，然后再焊接ANT_IN引脚；
- 9) 处理ANT_IN引脚时，请不要接触任何带电电容或材料（例如表贴天线、同轴电缆、电烙铁等），以免所述电容或材料所产生或存储的电荷损坏ANT_IN引脚；
- 10) 请确保使用带电保护的电烙铁焊接ANT_IN引脚。

4. Assembling & Repairing Note / 装配及维修说明

4.1. Module Assembling Note / 模块装配说明

K823 is surface mounted, SMT welding is recommended for assembly.

K823为表贴式模块，推荐使用SMT的焊接方式进行装配。

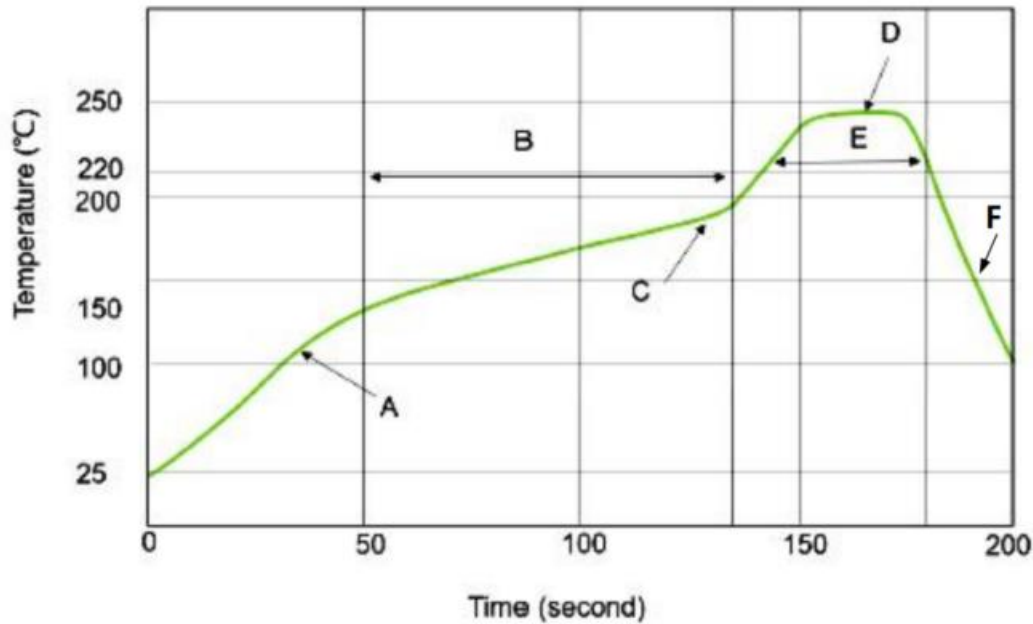

Figure 5. Furnace Temperature Curve / 炉温曲线

The process temperature limits are as follows:

- A: Heating Zone: Rising Slope: 1 ~ 3°C / sec
- B: Constant Temperature Zone: Range: 150 ~ 190 °C Time: 80 ~ 110 S
- C: Constant Temperature→Reflow Zone: Rising Slope: 1 ~ 3°C / sec
- D: Peak Temperature: 235 ~ 245°C
- E: Reflow Zone: Range: Over 220°C Time: 50 ~ 80 S
- F: Descent Slope: -5°C ~ -1°C / sec

制程温度界限如下：

- A: 升温区：斜率：1 ~ 3°C / sec
- B: 恒温区：150 ~ 190°C 时间：80 ~ 110S
- C: 恒温→回流区：斜率：1 ~ 3°C / sec
- D: 峰值温度：235 ~ 245°C
- E: 回流区：大于 220°C 时间：50 ~ 80S
- F: 下降斜率：-5 ~ -1°C / sec

In order to prevent the module from being damaged by repeated heating, it is recommended to place the module after finishing the first side of PCB board.

为避免模块因反复受热而损坏，建议在完成PCB板第一面的回流焊之后再贴模块。

4.2. Repairing Note / 维修说明

When disassembling the module, it is suggested using a BGA welding bench. Please use correct air tuyere and choose certain temperature curve. Keep peak temperature under 245°C, rising slope under 3°C/s.

拆卸模块时，请使用BGA返修台，选择适合尺寸的风嘴并使用合适的温度曲线，最高温度不超过245°C，升温斜率不超过3°C/s。

5. Application Connection Example / 应用连接示例

In this section, an application connection example of K823 OEM Module is presented via specific schematic diagrams. Per the instruction of these diagrams, you could easily build the communication circuits between K823 OEM Module and other terminals such as PC, GPRS or Bluetooth module, and some other devices with an UART.

本部分以具体电路的形式提供一个K823模块应用连接示例。参照下面的图示，您可以很方便建立K823模块和其他终端（如PC，GPRS模块，蓝牙模块或其他带有UART的设备）之间的通讯电路。

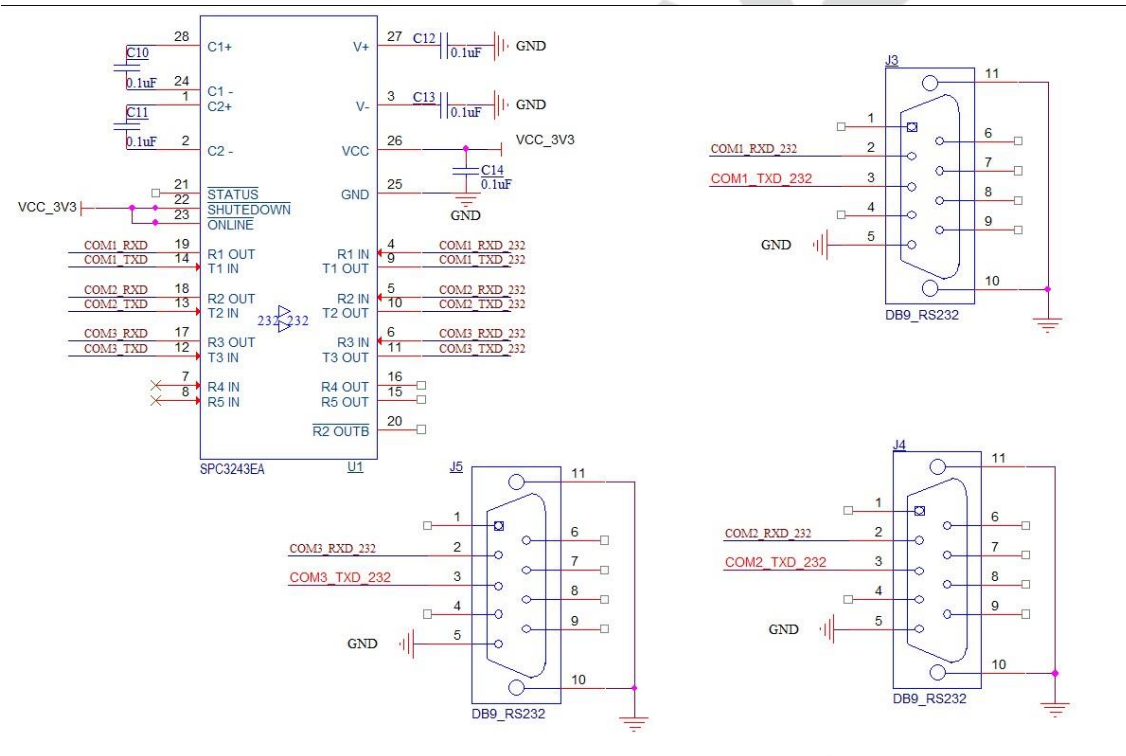

Figure 6. Connections between RS232 COM1, 2, 3 of K823 and Some Other Devices with An UART / K823 RS232 COM1、2、3与其他使用UART接口的设备之间的连接示意

©2024, ComnavTechnology Ltd. All rights reserved. SinoGNSS is the trade mark of Comnav Technology Ltd, registered in People's Republic of China. All other trademarks are the property of their respective owners.

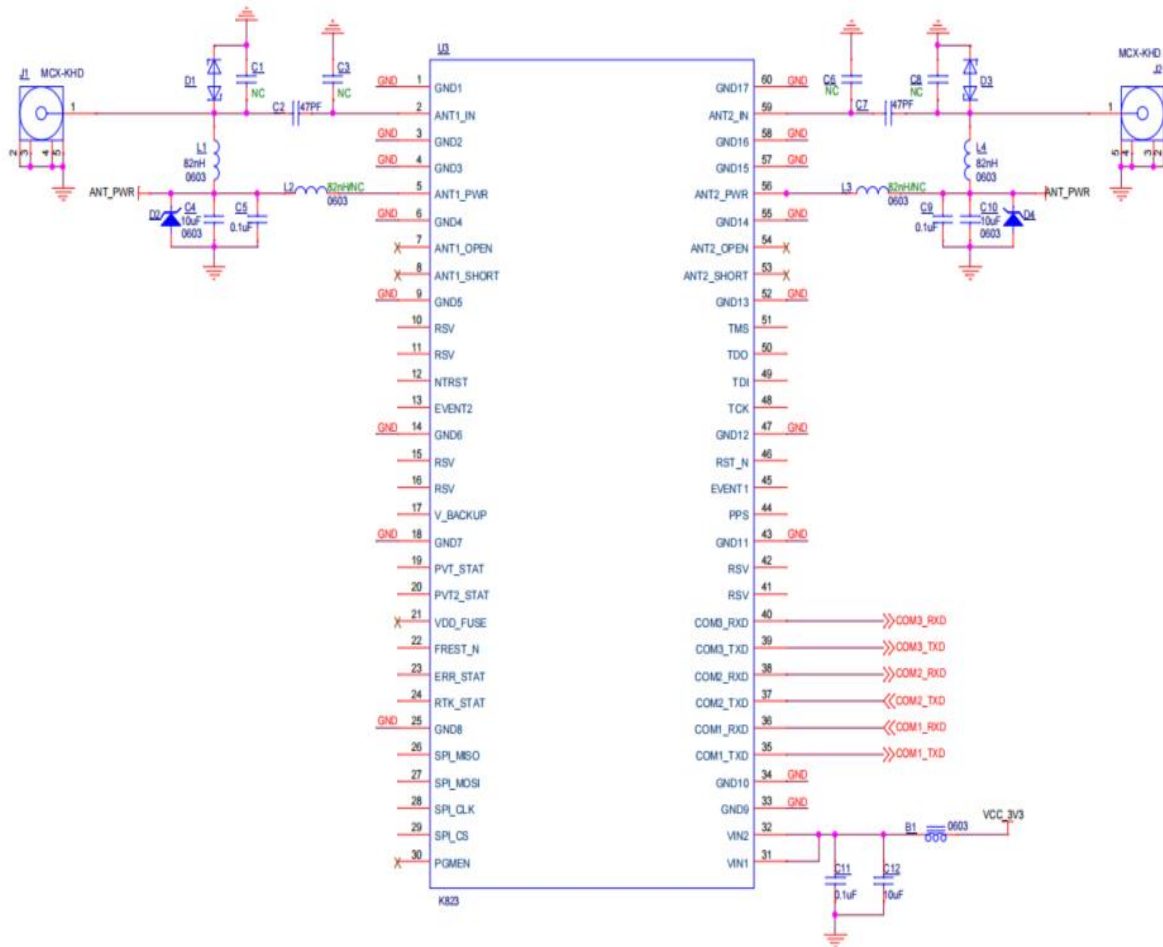

Figure 7. Minimum Hardware Design of K823 / K823 最小硬件设计

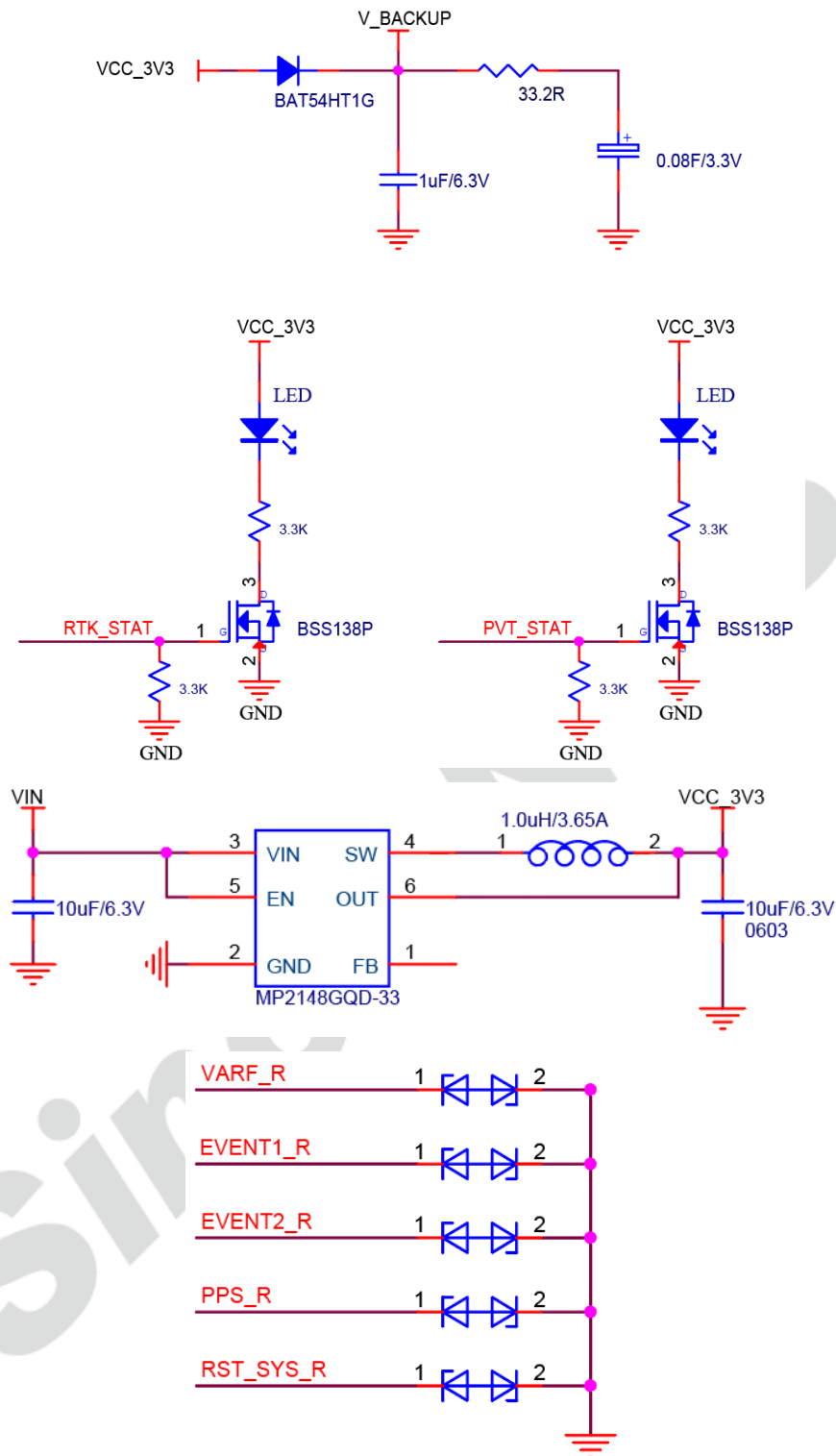

Figure 8. Recommend Design of K823 / K823 推荐硬件设计

6. Package / 包装

K823 module is packaged in a vacuum-sealed aluminum foil electrostatic bag containing desiccant and moisture proof by means of carrier tape and coil (applicable to mainstream surface mount equipment). When welding modules by reflow soldering process, please strictly comply with IPC standards for humidity control of modules. Because the packing materials such as the carrier belt can only withstand 55°C, the modules need to be removed from the packaging during baking operation.

K823模块使用载带、卷盘方式（适用于主流表面贴装设备），包装在真空密封的铝箔防静电袋中，内含干燥剂防潮。采用回流焊工艺焊接模块时，请严格遵守IPC标准对模块进行湿度管控。由于载带等包装材料只能承受55°C，在进行烘烤作业时需要将模块从包装中取出。

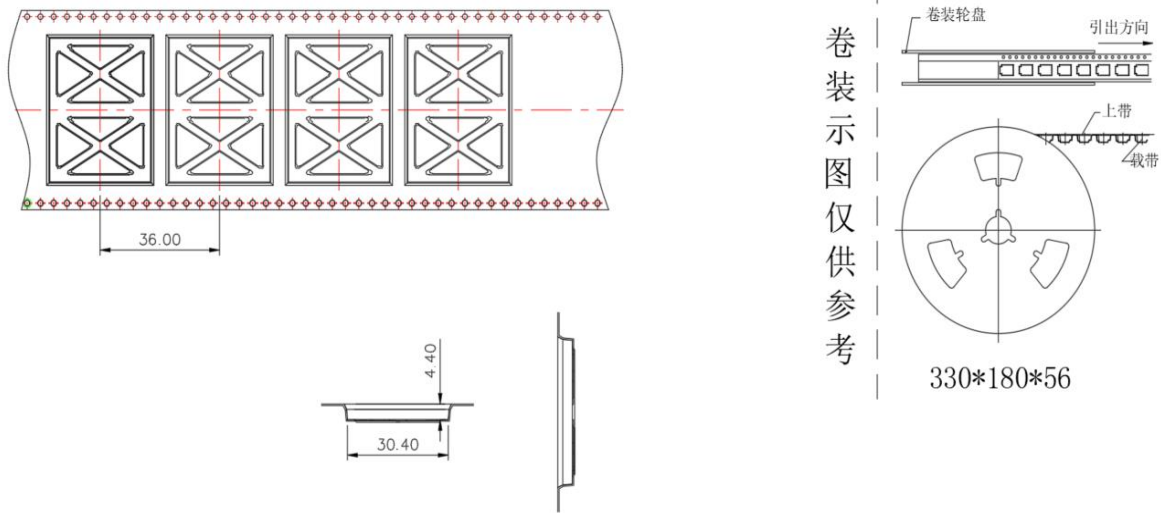

Figure 9. K823 Roll Tape Packing / K823 卷带包装

Table 5. K823 Package Description / K823 包装说明

Project	Description
Number of Modules 模块数量	250 Slice/Roll 250 片/卷
Reel Size 卷盘尺寸	Material tray:13 inches 料盘: 13 寸
	Outer diameter: 330mm, inner diameter: 180mm, width: 56mm, wall thickness: 4.4mm

©2024, ComnavTechnology Ltd. All rights reserved. SinoGNSS is the trade mark of Comnav Technology Ltd, registered in People's Republic of China. All other trademarks are the property of their respective owners.

	外径 330mm, 内径 180mm, 宽 56mm, 壁厚 4.4mm
	Package of each module: length 40.4mm, width 30.4mm 每个模块包装: 长 40.4mm, 宽 30.4mm
Carrier Belt 载带	Module Spacing (Center Distance): 36mm 模块间距 (中心距) : 36mm

上海司南导航技术股份有限公司

Comnav Technology, LTD.

上海市嘉定区澄浏中路618号2号楼

Building 2, 618 Chengliu Middle Road, Jiading District, Shanghai

官方网站: www.sinognss.com

热线: 400-060-8030



©2024, Comnav Technology Ltd. All rights reserved. SinoGNSS is the trade mark of Comnav Technology Ltd, registered in People's Republic of China. All other trademarks are the property of their respective owners.